



Please dispose of packaging for the product in a responsible manner. It is suitable for recycling. Help to protect the environment, take the packaging to the local amenity tip and place into the appropriate recycling bin.



Never dispose of electrical equipment or batteries in with your domestic waste. If your supplier offers a disposal facility please use it or alternatively use a recognised re-cycling agent. This will allow the recycling of raw materials and help protect the environment.

Chargestar Smart 18 Automatic



FOR HELP OR ADVICE ON THIS PRODUCT PLEASE CONTACT YOUR DISTRIBUTOR, OR SIP DIRECTLY ON:

TEL: 01509500400

EMAIL: sales@sip-group.com or technical@sip-group.com

www.sip-group.com

03981

Please read and fully understand the instructions in this manual before operation. Keep this manual safe for future reference.

Declaration of Conformity

We

SIP (Industrial Products) Ltd
Gelders Hall Road
Shepshed
Loughborough
Leicestershire
LE12 9NH
England

As the manufacturer's authorised representative within the EC
declare that the

Chargestar Smart 18 Automatic - SIP Part No. 03981

Conforms to the requirements of the following directive/s, as indicated.

2006/95/EC	Low Voltage Directive
2006/42/EC	Machinery Directive
2004/108/EC	EMC Directive
2002/95/EC	ROHS Directive
As Amended By 2008/35/EC	

And The Relevant Harmonised Standard/s, Including

EN 55014-1:2006+A1:2009+A2:2011
EN 55014-2:1997+A1:2001+A2:2008
EN 61000-3-2:2006+A1:2009+A2:2009
EN 61000-3-11:2000
EN 60204-1:2006+A1:2009
EN 609-1:1999+A1:2003+A2:2009

Signed: 

Mr P. Ippaso - Managing Director - SIP (Industrial Products) Ltd
Date: 28/02/2015.



EXPLODED DIAGRAM & PARTS LIST

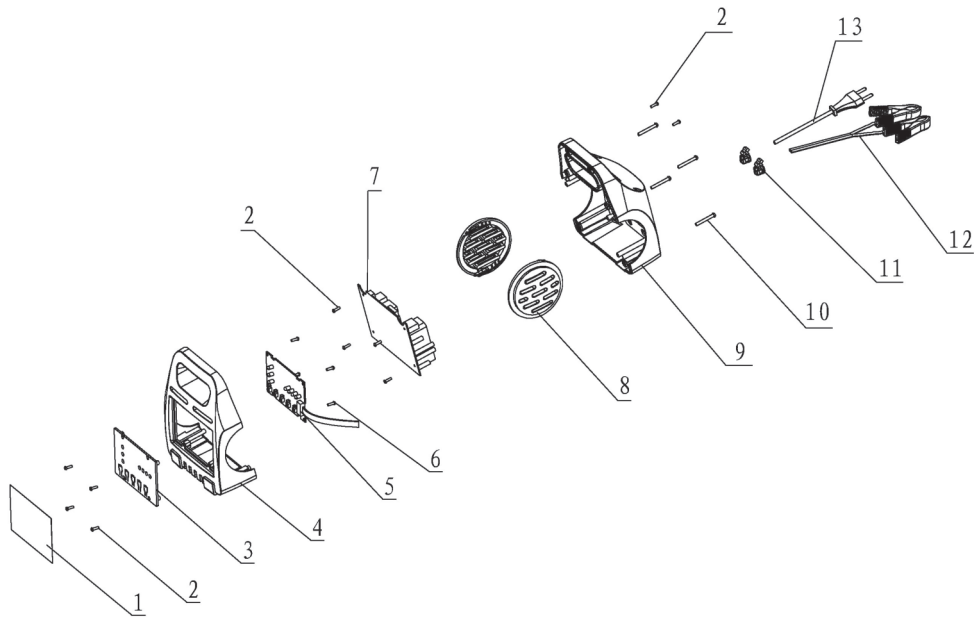

Ref. No.	Description	Sip Part No.	Ref. No.	Description	Sip Part No.
1.	Front panel label	PW02-00160	8.	Side cover	PW02-00167
2.	Screw M3x12	PW02-00161	9.	Rear cover	PW02-00168
3.	Panel	PW02-00162	10.	Screw M3x16	PW02-00169
4.	Front cover	PW02-00163	11.	Lead grips	PW02-00170
5.	Control PCB	PW02-00164	12.	Charging leads	PW02-00171
6.	Screw M3x10	PW02-00165	13.	Mains lead	PW02-00172
7.	PCB	PW02-00166			

CONTENTS

Page No.	Description
4.	Safety Symbols Used Throughout This Manual
4.	Safety Instructions
7.	Electrical Connection
8.	Guarantee
8.	Technical Specifications
9.	Getting to Know Your Charger
10.	Operating Instructions
13.	Troubleshooting
13.	Maintenance
14.	Exploded Diagram & Parts List
15.	Declaration of Conformity

SAFETY SYMBOLS USED THROUGHOUT THIS MANUAL



Danger / Caution: Indicates risk of personal injury and/or the possibility of damage.



Note: Supplementary information.

SAFETY INSTRUCTIONS



IMPORTANT: Please read the following instructions carefully, *failure to do so could lead to serious personal injury and / or damage to the charger.*

When using your charger, basic safety precautions should always be followed to reduce the risk of personal injury and / or damage to the charger.

Read all of these instructions before operating the charger and save this user manual for future reference.

The charger should **not** be modified or used for any application other than that for which it was designed.

The charger was designed to charge and maintain 6v/12v batteries.

If you are unsure of its relative applications do not hesitate to contact us and we will be more than happy to advise you.

Before operating the charger always check no parts are broken, that the positive/negative cables are not frayed, and that no parts are missing.

Always operate the charger safely and correctly.

KNOW YOUR CHARGER: Read and understand the owner's manual and labels affixed to the charger. Learn its applications and limitations, as well as the potential hazards specific to it.

DO NOT USE THE CHARGER IN DANGEROUS ENVIRONMENTS: Do not use your charger in damp or wet locations, or expose it to rain / water. Always provide adequate space around the charger.

KEEP CHILDREN AND UNTRAINED PERSONNEL AWAY FROM THE WORK AREA: All visitors should be kept at a safe distance from the work area.

STAY ALERT: Always watch what you are doing and use common sense.

DISCONNECT THE CHARGER FROM THE MAINS SUPPLY: When not in use.

DO NOT ABUSE THE MAINS LEAD: Never pull the mains lead to remove the plug from the mains socket. Keep the mains lead away from heat, oil and sharp edges. If the mains lead is damaged, it must be replaced by the manufacturer or its service agent or a similarly qualified person in order to avoid unwanted hazards.

TROUBLESHOOTING

If the fault light comes on then it could be the following reasons:

- Reverse polarity.
- Short circuit.
- Clamps not connected.
- Battery voltage too low or faulty battery

MAINTENANCE

With only minimal maintenance, this battery charger will deliver years of dependable service. Follow these simple steps to maintain the optimum condition:

- After each use, clean the battery charger clamps, be sure to remove any battery fluid that will cause corrosion of the copper clamps.
- Clean the outer case with a soft cloth.
- Keep the charger leads loosely coiled during storage to prevent damage.

OPERATING INSTRUCTIONS...cont

- After the clamps are attached to the terminals of the battery, slightly rotate them so as to remove any dirt or oxidization, this will ensure a good contact.
- The charger should then be connected to the mains supply and switched on.



Step 1 - Select the correct voltage of the battery.

Step 2 - Select the battery type, consult the manufacturer if unsure.

Step 3 - Select the charging rate.

Step 4 - Press go to start the charging process, once the battery is fully charged the green full light will come on.



Note: If any incorrect steps are selected, just press the go switch as this will take you back to step 1.

Note: The percentage light will flash between each percentage rating depending on the state of the battery, they do not stay on as a solid light.

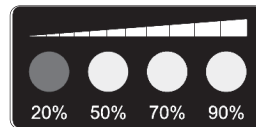

Battery Type	Slow Charging	Fast Charging
GEL	2 amp for 5 - 40Ah	4 amp for 20Ah-80Ah
AGM		12 amp for 20Ah-160Ah
WET		12 amp for 20Ah-160Ah

For all 6v batteries , the charger will give 7.5V constant voltage charge.

SAFETY INSTRUCTIONS...cont

HAVE YOUR CHARGER REPAIRED BY A QUALIFIED PERSON: The charger is in accordance with the relevant safety requirements. Repairs should only be carried out by qualified persons using original spare parts, otherwise this may result in considerable danger to the user, and void your warranty.

- **DANGER!** Check that the charger is in sound condition and good working order. Take immediate action to repair or replace damaged parts.
- **USE RECOMMENDED PARTS ONLY** - Unapproved parts may be dangerous and will invalidate the warranty.
- **WARNING!** Only operate on a level and stable surface.
- **WARNING!** Do not allow untrained persons to operate the charger and do not operate the charger without all covers etc. correctly fitted.
- **WARNING! RISK OF ELECTRIC SHOCK:** Do not expose the charger to water spray, rain, dripping water or moisture of any kind.
- Do not move the charger whilst it is charging.
- Do not allow children or animals near the charger, particularly when in use.
- Ensure that the charger is correctly turned off when not in use and stored in a safe, dry area, out of reach of children.
- Never stand on the charger.
- Do not dismantle or tamper with the charger, as this may be dangerous and will invalidate the warranty.
- Use only the electrical power (voltage and frequency) specified on the model plate on the charger. If in doubt contact the manufacturer.
- Use only a three-prong, grounded / earthed mains supply.
- It should not be used as a DC power source, or used to recharge non-rechargeable batteries. To do so may cause fire, electric shock, etc.
- If repairs are required, they should be performed by a suitably qualified person. Incorrect reassembly may result in a fire hazard and / or electric shock.
- Always disconnect the charger from any connected battery and the mains supply prior to cleaning the casing or changing fuses etc.
- Always check with the manufacturer of the vehicle to be started that it is safe to use an external power source.
- ALWAYS locate the charger in an area of good ventilation.
- Keep all combustible materials away from this charger.

Connecting the charger to a vehicle's battery:

FOR NEGATIVE EARTH VEHICLES (negative terminal of the battery is connected to the chassis/body of the vehicle): Connect the positive (red) clamp from the charger to the positive terminal (+) on the battery first. Then connect the negative (black) clamp to the negative terminal on the engine (ground) or the car chassis as far as practical from the battery and fuel line (a spark can be generated when connecting the second clip which can ignite battery or fuel gases).

SAFETY INSTRUCTIONS...cont

FOR POSITIVE EARTH VEHICLES (positive terminal of the battery is connected to the chassis/body of the vehicle): Connect the negative (black) clamp from the charger to the negative terminal (-) on the battery first. Then connect the positive (red) clamp to the positive terminal on the engine (ground) or the car chassis as far as practical from the battery and fuel line (a spark can be generated when connecting the second clip which can ignite battery or fuel gases).

During charging, batteries give off hydrogen and oxygen creating a highly explosive mix. Ensure adequate ventilation exists and avoid sparks, smoking, etc.

During battery maintenance ensure adequate clean water is available in the event of an acid spill. The liquid inside batteries is highly corrosive therefore ensure that it is not allowed to make contact with the skin (especially eyes). In the event of contact, flush the area with clean water and immediately consult a doctor.

Batteries store a large amount of energy. Short-circuiting a battery or charger terminals will cause the battery to try and release this energy immediately, which can result in fire or personal injury. Prevent any metal object (or other conductive material) from touching the + and - terminals of the charger or battery at the same time.

If a problem with the charger is experienced, or if the mains lead or plug become damaged, contact your distributor for repair.

If the charger is to be used on business premises - ensure that all local and national regulations are followed concerning the use of portable appliance at work.

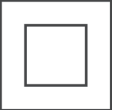

This charger is double insulated; This means the operator is separated from the tool's electrical system by two complete sets of electrical insulation. This extra layer of insulation is intended to protect the user from electrical shock due to a break in the wiring insulation. All exposed metal parts are isolated from the internal metal motor components with protecting insulation. Double insulated tools do not need to be grounded (earthed). Servicing of a tool with double insulation requires extreme care and knowledge of the system and should be performed only by a suitably qualified person



Caution: The warnings and cautions mentioned in this user manual can not cover all possible conditions and situations that may occur. It must be understood by the operator that common sense and caution are factors which cannot be built into this product, but must be applied.

OPERATING INSTRUCTIONS...cont



Danger / Caution: Never attempt to charge a frozen battery.

Preparing to charge:

- Determine the voltage of the battery by referring to the car owners manual.
- To remove the battery from the vehicle to charge always remove the negative terminal (-) from the battery first. Make sure all accessories in the vehicle are off, so as not to cause an arc.
- Clean the battery terminals, be careful to keep corrosion from coming in to contact with eyes.
- Add distilled water in each cell until the battery acid reaches level specified by the battery manufacturer. This helps purge excessive gas from the cells. Do not overfill. For a battery without cell caps, carefully follow the manufacturers re-charging instructions.
- Study all battery manufacturers specific precautions such as removing or not removing cell caps while charging and recommended rates of charge.
- Be sure the area around battery is well ventilated whilst the battery is being charged. Gas can be force blown away by using a piece of cardboard or other nonmetallic material such as a fan.
- Make sure the initial charging rate is not over the battery manufacturers suggestion.

Charging a battery:

- Remove the battery caps to allow any excess gas to escape and to prevent the case bursting.
- Check the battery liquid and top up if required.
- Attach the red clamp to the + terminal on the battery.
- Attach the black clamp to the - terminal on the battery.



Note: If the battery is still connected to the vehicle, connect one lead to the battery first (normally +). The other connection is to be made to the chassis as far away as practical from the battery and fuel line.



Important: Check with the manufacturer of the vehicle that the battery can be charged whilst still connected to avoid any unwanted damage to the vehicle.

OPERATING INSTRUCTIONS

The charger has 3 charging stages as follows:

STAGE 1 - BULK CHARGE (20% - 70%)

In this stage the charger delivers a maximum charging amperage to "wake up" the 12 volt battery. When it reaches a maximum safe pre-determined voltage, the digital sensors automatically move into stage 2 of the charging process.

STAGE 2 - ABSORPTION CHARGE (70% - 90%)

During this stage the charging voltage remains constant, whilst the charging current is controlled by the microprocessor.

STAGE 3 - MAINTENANCE CHARGE (90% - 100%)

In the final stage, the charging voltage is automatically maintained and reduced to a pre-determined level, whilst the charging current is adjusted for a safe, effective 100% charge by the microprocessor. Ideal for topping off batteries that have been in storage, the charger will automatically shut off at 100% charge.

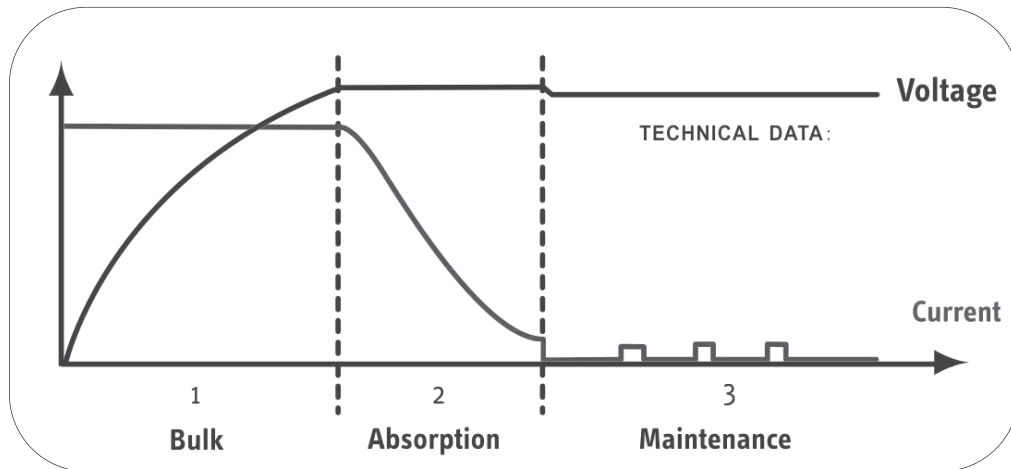

ELECTRICAL CONNECTION

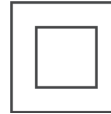

This charger is double insulated. This means the operator is separated from the tool's electrical system by two complete sets of electrical insulation.

This charger is fitted with a standard UK type 230v ~ plug. Before using the charger inspect the cable and plug to ensure that neither are damaged. If any damage is visible have the charger inspected / repaired by a suitably qualified person. If it is necessary to replace the plug a heavy duty impact resistant plug would be preferable.

The wires for the plug are coloured in the following way:

Blue	Neutral
Brown	Live

As the colours of the wires may not correspond with the markings in your plug, proceed as follows:

- The wire which is coloured blue, must be connected to the terminal marked with N or coloured black.
- The wire which is coloured brown, must be connected to the terminal, which is marked L or coloured red.
- Always secure the wires in the plug terminal carefully and tightly. Secure the cable in the cord grip carefully.



Warning: Never connect live or neutral wires to the earth terminal of the plug. Only fit an approved plug with the correct rated fuse. If in doubt consult a qualified electrician.



Note: Always make sure the mains supply is of the correct voltage and the correct fuse protection is used. In the event of replacing the fuse always replace the fuse with the same value as the original.



Note: If an extension lead is required in order to reach the mains supply; ensure that this too is rated for the correct voltage and fuse rating.



Note: The cross section of the extension lead should be checked so that it is of sufficient size so as to reduce the chances of voltage drops.

GUARANTEE

This SIP charger is covered by a 12 month parts and labour warranty covering failure due to manufacturers defects. This does not cover failure due to misuse or operating the charger outside the scope of this manual - any claims deemed to be outside the scope of the warranty may be subject to charges including, but not limited to parts, labour and carriage costs.

This guarantee does not cover consumables such as fuses, cables etc.

In the unlikely event of warranty claims, contact your distributor as soon as possible.



Note: Proof of purchase will be required before any warranty can be honoured.

TECHNICAL SPECIFICATIONS

Part No.	03981
Description	Chargestar Smart 18 Automatic
Input Voltage	230v ~
Input Fuse Rating	13 A
Charging Voltages	6v & 12v
Max. Current Output - Slow	2 amp
Max. Current Output - Fast	12 amp
Rated Battery Capacity	40Ah - 160Ah
Battery Type	Gel, AGM, Wet Cell

For all 6v batteries , the charger will give 7.5V constant voltage charge.

GETTING TO KNOW YOUR CHARGER

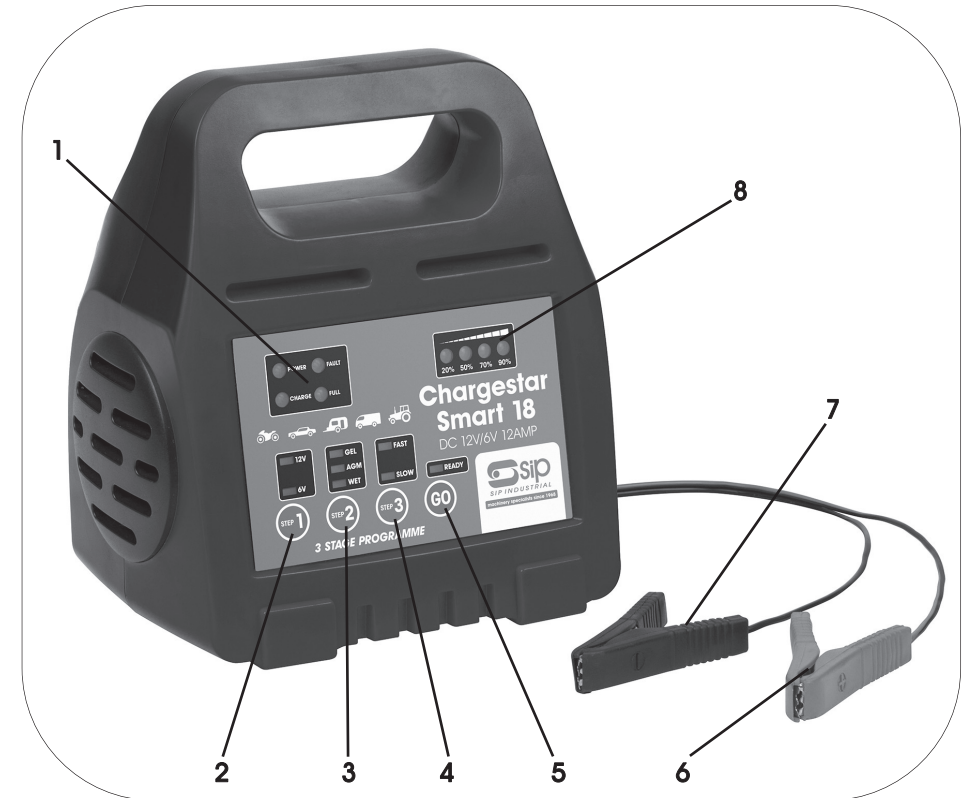

Ref. No.	Description	Ref. No.	Description
1.	Indication LED	5.	Go (start charging button)
2.	6v / 12v Button	6.	Positive Clamp
3.	Battery Type Button	7.	Negative Clamp
4.	Charge Rate Button	8.	Charge Level Indication